

Kit 1565

FORD Focus, 3-dr Hatchback, *98-03, 04-

FORD Focus, 5-dr Hatchback, *98-03, 04-

FORD Focus, 4-dr Sedan, *98-03, 04-

FORD Focus, 5-dr Wagon, *98-03, 04-

*North America

480R
754

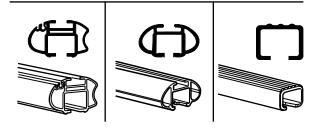
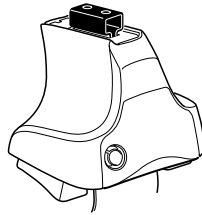

480

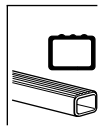
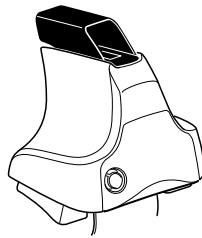

750

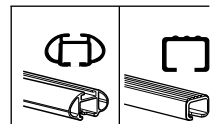
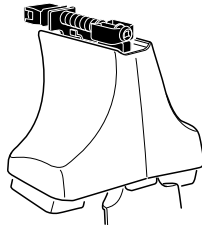





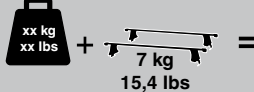

THULE[®]
SWEDEN

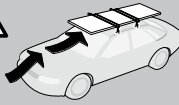



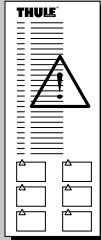

ISO 11154-E



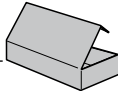

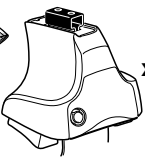
Max. 60kg
Max. 132 lbs







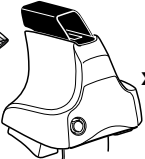



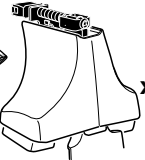











480R/754



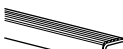



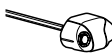

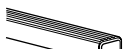
480

750

				
 x2  x2  x2  x4	 x2	 x2  x2  x4  x4	 x2  x2	 x2



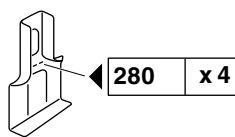
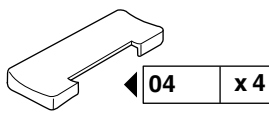

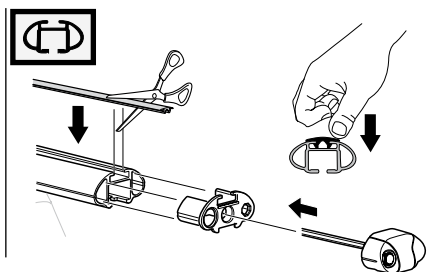
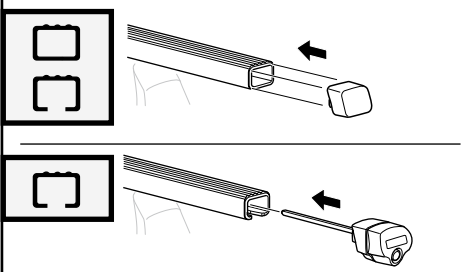
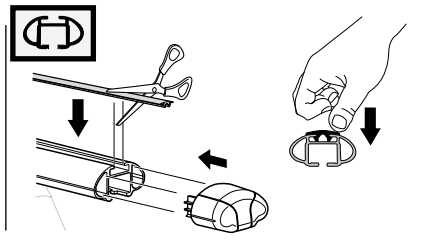
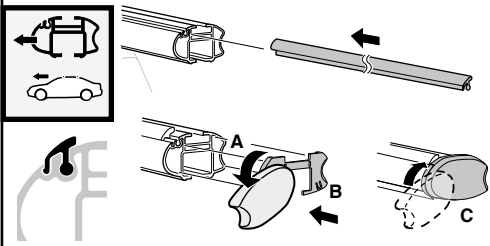

Kit

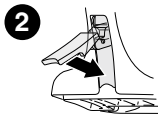
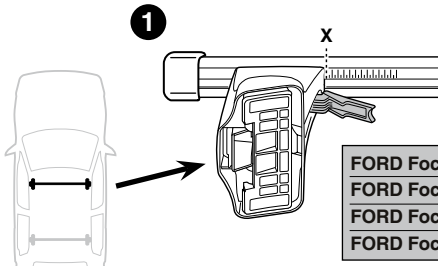

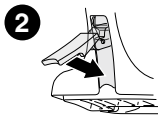
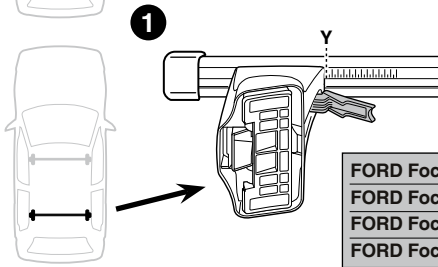

	X
FORD Focus, 3-dr Hatchback, *98-03, 04-	33,5
FORD Focus, 5-dr Hatchback, *98-03, 04-	32,5
FORD Focus, 4-dr Sedan, *98-03, 04-	32,5
FORD Focus, 5-dr Wagon, *98-03, 04-	32



	Y
FORD Focus, 3-dr Hatchback, *98-03, 04-	28
FORD Focus, 5-dr Hatchback, *98-03, 04-	29
FORD Focus, 4-dr Sedan, *98-03, 04-	30
FORD Focus, 5-dr Wagon, *98-03, 04-	28,5

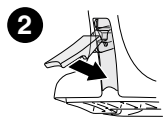
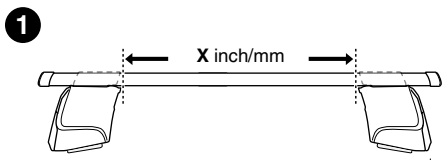
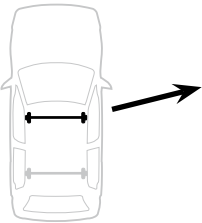
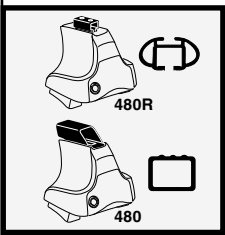

	X inch	X mm
FORD Focus, 3-dr Hatchback, *98-03, 04-	38 ⁷ / ₈ "	986 mm
FORD Focus, 5-dr Hatchback, *98-03, 04-	38 ³ / ₈ "	976 mm
FORD Focus, 4-dr Sedan, *98-03, 04-	38 ³ / ₈ "	976 mm
FORD Focus, 5-dr Wagon, *98-03, 04-	38 ¹ / ₄ "	971 mm

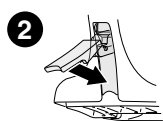
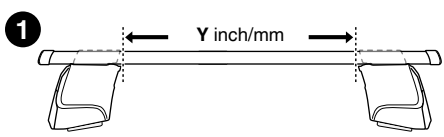
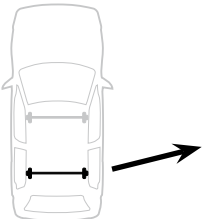

	X inch	X mm
FORD Focus, 3-dr Hatchback, *98-03, 04-	36 ⁵ / ₈ "	931 mm
FORD Focus, 5-dr Hatchback, *98-03, 04-	37	941 mm
FORD Focus, 4-dr Sedan, *98-03, 04-	37 ¹ / ₂ "	951 mm
FORD Focus, 5-dr Wagon, *98-03, 04-	36 ⁷ / ₈ "	936 mm

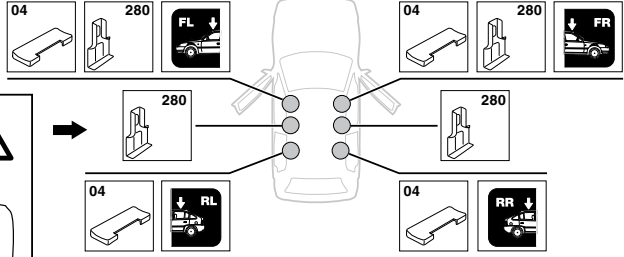
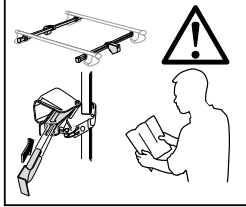
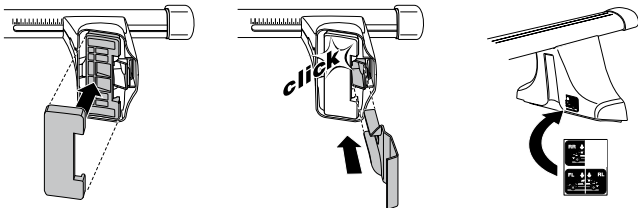
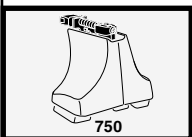
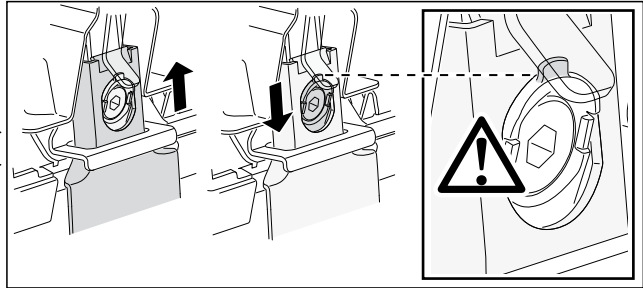
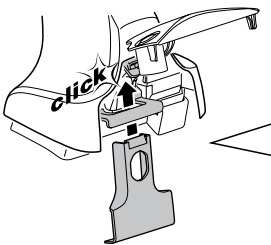
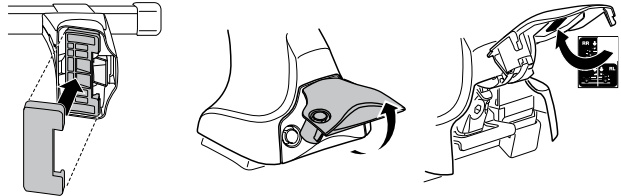
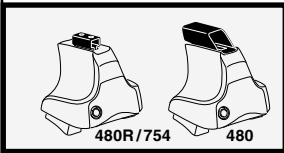
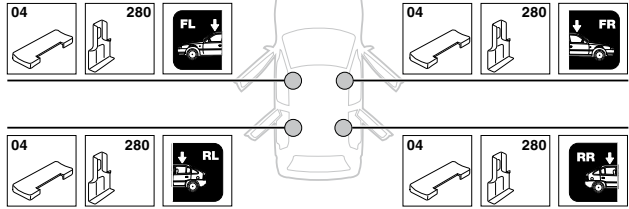
4**FORD Focus, 3-dr Hatchback, *98-03, 04-****SRA****FORD Focus, 5-dr Hatchback, *98-03, 04-****FORD Focus, 4-dr Sedan, *98-03, 04-****FORD Focus, 5-dr Wagon, *98-03, 04-**

5

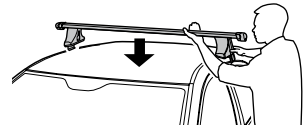
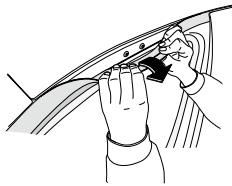
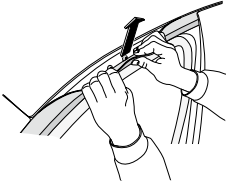

FORD Focus, 3-dr Hatchback, *98-03, 04-

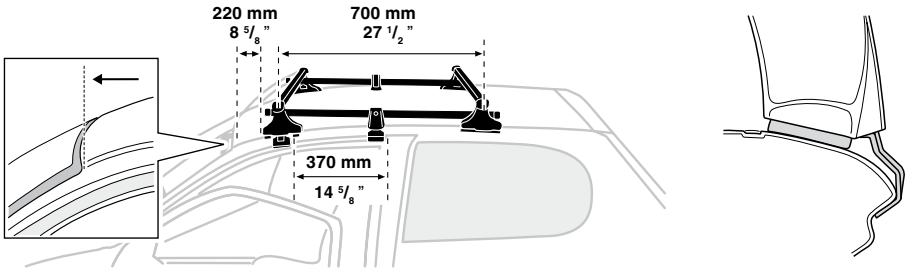

	X mm	Y mm	X inch	Y inch
FORD Focus, 5-dr Hatchback, *98-03, 04-	220 mm	630 mm	8 5/8"	24 3/4"
FORD Focus, 4-dr Sedan, *98-03, 04-	220 mm	630 mm	8 5/8"	24 3/4"
FORD Focus, 5-dr Wagon, *98-03, 04-	220 mm	630 mm	8 5/8"	24 3/4"

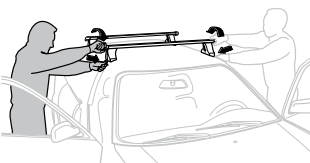
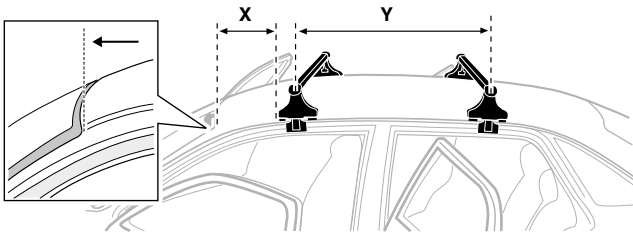

- GB/US** Tighten alternately
D Die Schrauben abwechselnd anziehen
F Serrer alternativement chaque côté
NL Afwisselend aan de linker- en de rechterkant aandraaien
I Alternare il serraggio delle viti
E Apretar alternativamente
PT Aperte alternadamente
S Dra åt växelvis
FIN Kierrä vuorotellen
EST Pinguldage vaheldumisi
LAT Pievelciēt pamišus
LIT Užsukinėkite pakaitomis
PL Śruby dokręcaj naprzemiennie
RU Затягивайте попеременно

- CZ** Pokrétta багаžníka dokręcaj dokręcaj naprzemiennie.
SK Doťahujte striedavo
SLO Privijajte izmenično.
HR Naizmjenično zategnite
HU Egymástól függetlenül szorítandó
GR Σφιγγεται εναλλάξ
TR Dönüşümlü sıkın

中文 交替拧紧

한국어 번갈아 가며 조이십시오.

日本語 交互に締め付けてください。

ไทย ขั้นโน้แบบบสลับ

6



480R/754



480



*
3 Nm



*



*
≈ 3 Nm

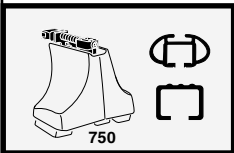

750

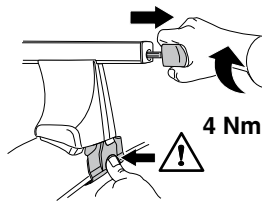

4 Nm

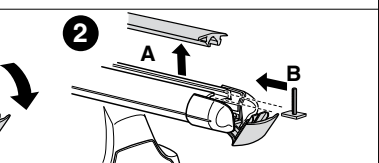
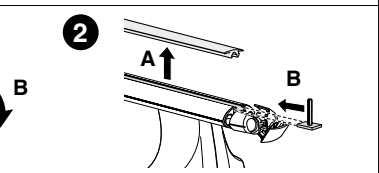
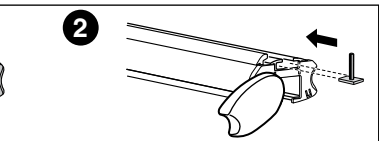
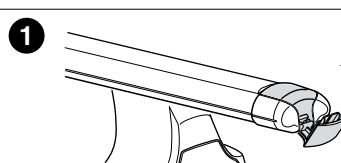
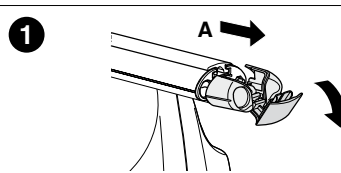
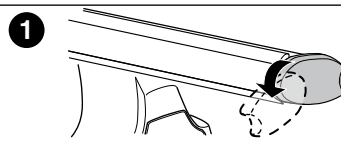
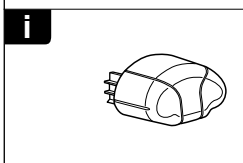
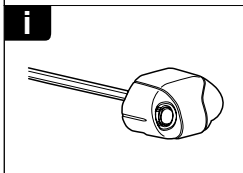
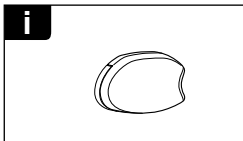
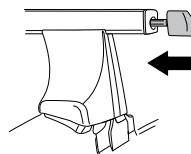



THULE
SWEDEN
**ONE
KEY
SYSTEM**



- 544 (x4)
- 596 (x6)
- 588 (x8)
- NA 510 (x10)
- EUR 452 (x12)
- ASIA



WW ▶ Thule Sweden AB, Box 69, 330 33 Hillerstorp, SWEDEN
NA ▶ Thule Inc., 42 Silvermine Road, Seymour, Connecticut 06483, USA

info@thule.com
customer.service@thule.com

www.thule.com